

DISPLAY | Countertop Displays

REFRIGERATED COUNTERTOP SHOWCASES

RC 120



GAS R600a	M2 -1°C +7°C	B ENERGY CLASS	4 +30°C/55RH
LED			

DETAILS

 Lateral and frontal curved glasses	 Stainless steel basement with digital controller	 Inner LED light
 Rear sliding doors		

GENERAL FEATURES

- 120 Lt. Refrigerated countertop showcase
- Curve glass with black frame and stainless steel basement
- Ventilated Cooling
- Automatic compressor cycle defrost
- Digital display control
- Interior LED light
- Anti-condensation double layer glass
- Rear sliding doors
- Adjustable chromed shelves (N.2 Pcs)
- N.4 fix support assembled under the basement
- Energy efficiency class: B

TECHNICAL SPECIFICATIONS

Capacity	120 L
Temperature	M2 (-1°C-+7°C)
Consumption	3.125 kWh/24h
Rated Power	230 W
Noise level	52 dB(A)
Net Weight	64 Kg
Gross Weight	71 Kg
External Dimensions (WxDxH mm)	695x570x685
Internal Dimensions (WxDxH mm)	665x485x410
Packaging dimensions (WxDxH mm)	773x627x855
Loading quantities 20'/40'/40'HQ	81/162/162

PRODUCT DIMENSIONS

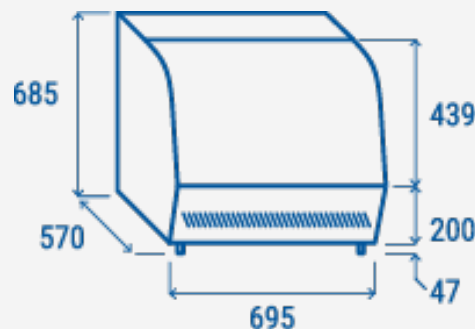

CERTIFICATION

CE RoHS

